



# Drill Bits

Product	Page
Twist Drills	5-1
Step Drills	5-4
Through-Hole Bits	5-5
Dowel Bits	5-12
Boring Spikes	5-25
Boring Countersink	5-26
Countersink Parts	5-27
Countersink Bits for Twist Drills	5-29
Cylinder Boring Bits	5-30
Technical Information	5-36

130010

### Twist Drills with solid carbide body

product

drawing

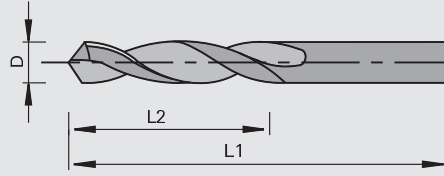

Solid Tungsten Carbide

MAN

**Machine / Application**

- | portable boring machines
- | automatic boring machines
- | CNC machining centers
- | for drilling of through holes and dowel holes in solid woods and wood-based panels

**Design**

- | 2 v-point cutting edges
- | solid carbide design
- | cutting  $\varnothing$  = shank  $\varnothing$
- | tip angle 120°

**Advantages**

- | high feed rates possible
- | large resharpenable area

**Notes**

- | clamping element: draw-in collet chuck, adapter Class-No. 333389, drill chuck

$\varnothing D$	L2	L1	Ident-No. [L]	Ident-No. [R]
2.0	25	50	182625	182626
2.5	27	55	182627	182628
3.0	27	55	182629	182630
3.5	27	52	182631	182632
4.0	27	55	182633	182634
5.0	28	60	182635	182636
[mm]	[mm]	[mm]		

130010

## Twist Drills HW

product

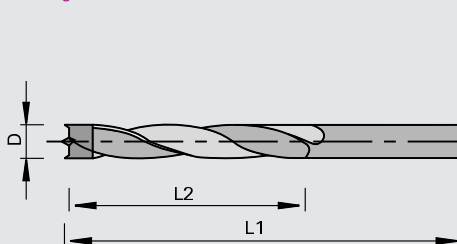

drawing

LEUCO  
DUR

tungsten carbide [HW]

MAN

## Machine / Application

- | portable boring machines
- | automatic boring machines
- | CNC machining centers
- | for chip-free drilling of dowel holes in solid woods and wood-based panels

## Design

- | centering point
- | cutting  $\varnothing$  = shank  $\varnothing$
- | 2 negative spurs
- | spiral with back-guide
- | plastic coated
- | HW-tipped

## Advantages

- | safe drilling thanks to centering point
- | protection of the hole edge upon exiting thanks to spiral with back guide
- | optimum chip evacuation thanks to plastic coating
- | chip-free hole edges thanks to negative spurs

## Notes

- | clamping element: draw-in collet chuck, drill chuck

$\varnothing$ D	L2	L1	Ident-No. [L]	Ident-No. [R]
5.0	35	70	173145 o	167929
6.0	35	70		167930 o
7.0	35	70		167931 o
8.0	35	70	173148 o	167932 o
10	35	70	173150 o	167934 o
11	35	70		167935 o
12	35	70		167936 o
4.0	55	80		160503
4.5	60	85		160504 o
5.0	60	90		160505
5.5	65	100		164243 o
6.0	65	100		160506
6.5	70	110		164244 o
7.0	70	110		160507 o
8.0	75	120		160508
8.5	80	130		164245 o
9.0	80	130		160509 o
10	90	140		160510
11	95	150		160511 o
12	100	155		160512
[mm]	[mm]	[mm]		

330010

## Twist Drills HS

product



drawing

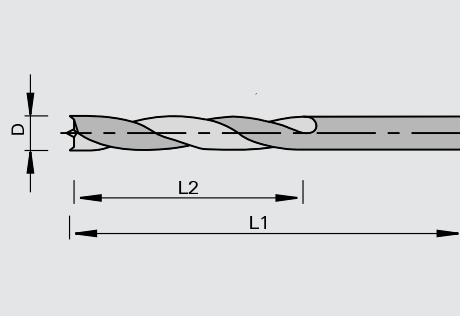

High Speed Steel [HS]

MAN

**Machine / Application**

- | portable boring machines
- | automatic boring machines
- | for drilling of dowel holes in solid woods

**Design**

- | 2 spurs
- | centering point
- | special coating
- | cutting  $\varnothing$  = shank  $\varnothing$
- | HS design

**Advantages**

- | chip-free hole edges thanks to spurs
- | safe drilling thanks to centering point
- | long edge lives thanks to special coating

**Notes**

- | clamping element: draw-in collet chuck, drill chuck

$\varnothing D$	L2	L1	Ident-No. [L]	Ident-No. [R]
2.0	22	49	167671	167669
2.5	25	57	167672	167670
3.0	30	61	160530	160518
3.5	35	70	160531 o	160519 o
4.0	40	75	160532	160520
4.5	45	80	160533 o	160521
5.0	45	83	160534	160522
5.5	50	90	160535 o	160523 o
6.0	50	90	160536 o	160524 o
6.5	55	98	177175 o	160525 o
7.0	60	105	177176 o	160526 o
7.5	60	105		177177 o
8.0	70	113	160539 o	160527
8.5	70	113		177178 o
9.0	75	120		160528 o
10	80	130		160529 o
[mm]	[mm]	[mm]		

330710

### Step Drills HS for drill-in hinges

product

drawing

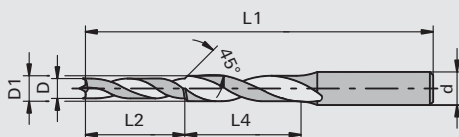

High Speed Steel [HS]

MAN

**Machine / Application**

- | automatic boring machines
- | CNC machining centers
- | for step-drillings for screw-in of drill-in hinges such as Anuba, Simons, etc

**Design**

- | 2 spurs
- | centering point
- | cylindrical shank without clamping surface
- | post-drill with countersink 45°
- | HS design

**Advantages**

- | safe drilling thanks to centering point

**Notes**

hinge size	Ø D	Ø D1	L4	L2	Ø d	L3	L1	Ident-No.
14.5	6.3	7.2	40	24	10	30	105	R 183092 o
16	6.7	7.7	35	30	10	30	105	R 183093 o
18	7.7	8.7	35	30	10	30	105	R 183094 o
20	8.8	9.8	35	30	10	30	105	R 183095 o
-	6	6.8	50	15	10	30	105	R 183096 o
[mm]	[mm]	[mm]	[mm]	[mm]	[mm]	[mm]	[mm]	



130012

## Through-Hole Bits HW

product



drawing

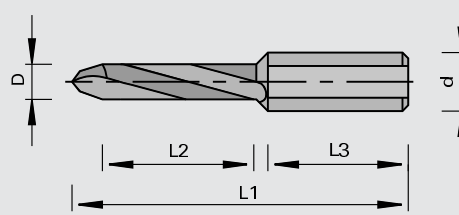

LEUCO  
topline

LEUCO  
DUR

tungsten carbide [HW]

MAN

### Machine / Application

- | portable boring machines
- | automatic boring machines
- | CNC machining centers
- | for drilling of through-holes in solid woods and wood-based panels

### Design

- | cylindrical shank with clamping surface
- | new cutting geometry
- | HW-tipped

### Advantages

- | increased edge lives compared to traditional through-hole bits thanks to special HW and special grinding
- | chip-free hole edges thanks to special cutting edge geometry

### Notes

- | adjusting screw Ident-No. 001600 M5x10 DIN 551 for precise length adjustment included in delivery
- | adjusting screw Ident-No. 181520 M5x11,5 for Weeke quick clamping chuck must be ordered separately
- | clamping elements: combi chuck, quick-change chuck
- | other dimensions possible with minimum quantities of 10 pieces; price and delivery time on request

Ø D	L2	Ø d	L3	L1	Ident-No. [L]	Ident-No. [R]
5	25	10	25	57.5	177804	177805
8	25	10	25	57.5	177806	177807
5	30	10	30	70	178648	178649
8	30	10	30	70	178650	178651
[mm]	[mm]	[mm]	[mm]	[mm]		

130013

## Mosquito Through-Hole Bits HW

product



drawing

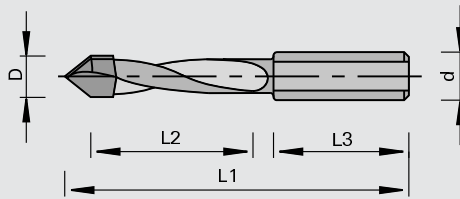

MOSQUITO

tungsten carbide [HW]

MAN

## Machine / Application

- | portable boring machines
- | automatic boring machines
- | CNC machining centers
- | for chip-free drilling of through-holes in solid woods and wood-based panels

## Design

- | special cutting edge geometry
- | HW-plunging tip made from super-fine grain material

## Advantages

- | chip-free hole edges thanks to special cutting edge geometry
- | long edge lives thanks to HW plunging tip
- | high process safety thanks to constant quality of the bores for a long time

## Notes

- | adjusting screw Ident-No. 001600 M5x10 DIN 551 for precise length adjustment included in delivery
- | adjusting screw Ident-No. 181520 M5x11,5 for Weeke quick clamping chuck must be ordered separately
- | clamping elements: combi chuck, quick-change chuck

Ø D	L2	Ø d	L3	L1	Ident-No. [L]	Ident-No. [R]
5	27	10	26	57.5	182458	182459
8	27	10	26	57.5	182460	182461
5	35	10	26	70	182462	182463
6	35	10	30	70	183689 o	183688 o
7	35	10	30	70	183691 o	183690 o
8	35	10	26	70	182464	182465
10	35	10	30	70	183693 o	183692 o
[mm]	[mm]	[mm]	[mm]	[mm]		



130013

## Mosquito Through-Hole Bits with solid carbide body

product

drawing

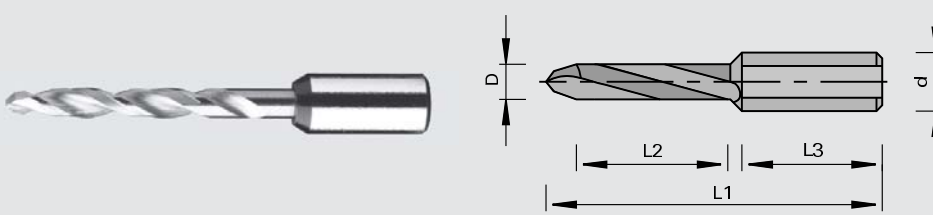

**MOSQUITO**

Solid Tungsten Carbide

MAN

**Machine / Application**

- | portable boring machines
- | automatic boring machines
- | CNC machining centers
- | for chip-free drilling of through-holes in solid woods and wood-based panels

**Design**

- | special cutting edge geometry
- | boring part made from fine-grain solid tungsten carbide

**Advantages**

- | chip-free hole edges thanks to special cutting edge geometry
- | high feed rates and edge lives increased up to sixfold compared to traditional dowel bits thanks to solid carbide design
- | high process safety thanks to constant quality of the bores for a long time

**Notes**

- | adjusting screw Ident-No. 001600 M5x10 DIN 551 for precise length adjustment included in delivery
- | adjusting screw Ident-No. 181520 M5x11,5 for Weeke quick clamping chuck must be ordered separately
- | clamping elements: combi chuck, quick-change chuck

Ø D	L2	Ø d	L3	L1	Ident-No. [L]	Ident-No. [R]
3	35	10	22	70	183687 o	183686 o
4	40	10	22	70	183167 o	183166 o
5	40	10	22	70	183153	183152
6	40	10	22	70	183155 o	183154 o
8	40	10	22	70	183157	183156
[mm]	[mm]	[mm]	[mm]	[mm]		

130011

## Ecoline Through-Hole Bits HW

product

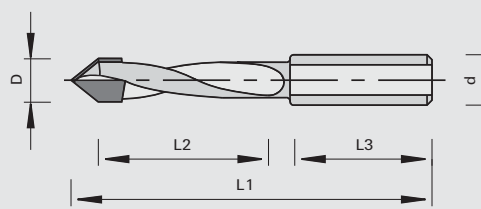

drawing

LEUCO  
DUR

tungsten carbide [HW]

MAN

## Machine / Application

- | portable boring machines
- | automatic boring machines
- | CNC machining centers
- | for drilling of through-holes in solid woods and wood-based panels

## Design

- | 2 v-point cutting edges with 60 degrees
- | cylindrical shank with clamping surface
- | spiral without back guide
- | plunging tip with carbide plate for reduced demands

## Advantages

## Notes

- | adjusting screw Ident-No. 001600 M5x10 DIN 551 for precise length adjustment included in delivery
- | adjusting screw Ident-No. 181520 M5x11,5 for Weeke quick clamping chuck must be ordered separately
- | clamping elements: combi chuck, quick-change chuck

Ø D	L2	Ø d	L3	L1	Ident-No. [L]	Ident-No. [R]
5	39	10	20	70	183389	183388
7	42	10	20	70	183391	183390
8	44	10	20	70	183393	183392
5	46	10	20	77	183395	183394
8	51	10	20	77	183397	183396
[mm]	[mm]	[mm]	[mm]	[mm]		

130015

## Through-Hole Bits HW

product

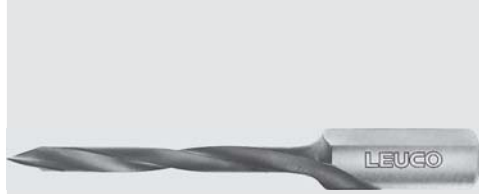

drawing

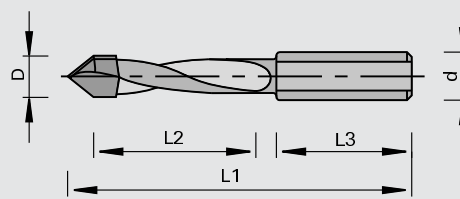

tungsten carbide [HW]

MAN

### Machine / Application

- | portable boring machines
- | automatic boring machines
- | CNC machining centers
- | for drilling of through-holes in solid woods and wood-based panels

### Design

- | 2 v-point cutting edges (60 degree angle)
- | HW-tipped
- | cylindrical shank with clamping surface
- | spiral without back guide

### Advantages

### Notes

- | adjusting screw Ident-No. 001600 M5x10 DIN 551 for precise length adjustment included in delivery
- | adjusting screw Ident-No. 181520 M5x11,5 for Weeke quick clamping chuck must be ordered separately
- | clamping elements: combi chuck, quick-change chuck

Ø D	L2	Ø d	L3	L1	Ident-No. [L]	Ident-No. [R]
4	27	10	25	57.5	182239 o	182240 o
5	25	10	25	57.5	055827	055823
5.1	25	10	25	57.5	176473 o	176472 o
6	25	10	25	57.5	176475	176474
7	27	10	25	57.5	182245 o	182246 o
8	22	10	25	57.5	055830	055826
3	27	10	25	70	182237 o	182238 o
4	35	10	25	70	182241	182242
5	35	10	25	70	176505	176504
5.5	35	10	25	70	182243 o	182244 o
6	35	10	25	70	176259	176258
7	35	10	25	70	181581	181582
8	35	10	25	70	176507	176506
10	35	10	25	70	182669 o	182670 o
11	35	10	25	70	182249 o	182250 o
5	45	10	25	77	176477	176476
6	45	10	25	77	176479	176478
7	45	10	25	77	182251 o	182252 o
8	43	10	25	77	176481	176480
9	42	10	25	77	182253 o	182254 o
10	42	10	25	77	176483	176482
11	40	10	25	77	182255 o	182256 o
12	40	10	25	77	176485	176484
[mm]	[mm]	[mm]	[mm]	[mm]		

130015

## Through-Hole Bits HW

product

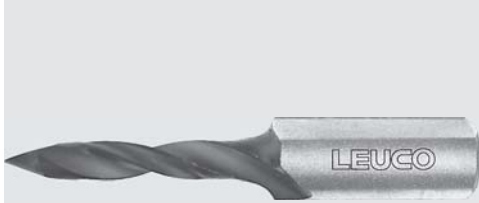

drawing

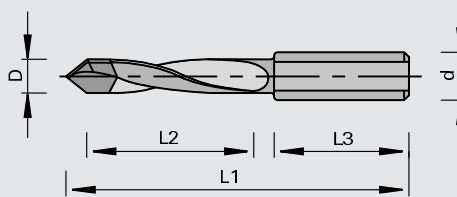
LEUCO  
DUR

tungsten carbide [HW]

MAN

## Machine / Application

- | portable boring machines
- | automatic boring machines
- | CNC machining centers
- | for drilling of through-holes in solid woods and wood-based panels

## Design

- | 2 v-point cutting edges (60 degree angle)
- | HW-tipped
- | cylindrical shank with clamping surface
- | spiral with back-guide

## Advantages

- | protection of the hole edge upon exiting thanks to spiral with back guide

## Notes

- | adjusting screw Ident-No. 001600 M5x10 DIN 551 for precise length adjustment included in delivery
- | adjusting screw Ident-No. 181520 M5x11,5 for Weeke quick clamping chuck must be ordered separately
- | adjustable countersink attachment on the boring spiral for simultaneous chamfering of the hole
- | shell countersink Class-No. 130660
- | clamping elements: combi chuck, quick-change chuck

Ø D	L2	Ø d	L3	L1	Ident-No. [L]	Ident-No. [R]
5	25	8	20	55.5	176497 o	176496 o
8	25	8	20	55.5	176499 o	176498 o
5	25	10	20	57.5	173604	173595
8	25	10	20	57.5	173611 o	173596 o
5	35	8	20	67	176501	176500
8	35	8	20	67	176503	176502
5	35	10	25	70	176255	176254
8	35	10	25	70	176257	176256
[mm]	[mm]	[mm]	[mm]	[mm]		

230012

## Through-Hole Bits DP

product

drawing

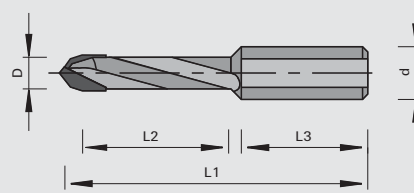

polycrystalline diamond [DP]

MEC

**Machine / Application**

- | automatic boring machines
- | CNC machining centers
- | for chip-free drilling in raw and laminated panels and composite materials

**Design**

- | special cutting edge geometry, roof-shaped tip and double chamfer
- | spiral without back guide
- | DP-tipped

**Advantages**

- | long edge life when machining extremely abrasive materials
- | chip-free hole edges thanks to special cutting edge geometry

**Notes**

- | adjusting screw Ident-No. 001600 M5x10 DIN 551 for precise length adjustment included in delivery
- | adjusting screw Ident-No. 181520 M5x11,5 for Weeke quick clamping chuck must be ordered separately
- | clamping elements: combi chuck, quick-change chuck

Ø D	L2	Ø d	L3	L1	Z	Ident-No. [L]	Ident-No. [R]
5	27	10	26	57.5	1	183015 s	183014 s
5	35	10	26	70	1	183017 s	183016 s
6	35	10	26	70	2	183019 s	183018 s
8	35	10	26	70	2	183021 s	183020 s
10	35	10	26	70	2	183049 s	183050 s
[mm]	[mm]	[mm]	[mm]	[mm]			

130215

## Dowel Bits HW

product

drawing

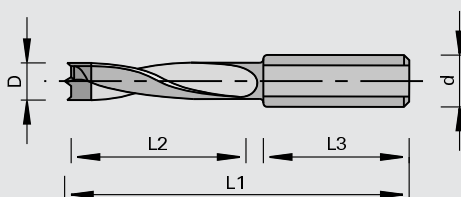

tungsten carbide [HW]

MAN

**Machine / Application**

- | portable boring machines
- | automatic boring machines
- | CNC machining centers
- | for chip-free drilling of dowel holes in solid woods and wood-based panels

**Design**

- | 2 negative spurs
- | centering point
- | spiral with back-guide
- | plastic coated
- | HW-tipped

**Advantages**

- | chip-free hole edges thanks to spurs
- | safe drilling thanks to centering point
- | protection of the hole edge upon exiting thanks to spiral with back guide
- | optimum chip evacuation thanks to plastic coating

**Notes**

- | adjusting screw: Ident-No. 001600 M5x10 DIN 551 for precise length adjustment
- | adjustable countersink attachment on the boring spiral for simultaneous chamfering of the hole
- | shell countersink Class-No. 130660
- | clamping element: combi chuck, quick-change chuck

Ø D	L2	Ø d	L3	L1	Ident-No. [L]	Ident-No. [R]
4	30	8	19	55.5	166107 o	166106 o
5	30	8	19	55.5	011543	011542
6	30	8	19	55.5	054884	054883
8	30	8	19	55.5	054892	054891
10	30	8	19	55.5	054896	054895
12	30	8	20	55.5	166113 o	166112 o
4	40	8	19	67		167154 o
5	40	8	19	67	057494	057493
6	40	8	19	67	057496 o	057495
7	40	8	19	67	167167	167157
8	40	8	19	67	057498	057497
9	40	8	19	67	167169	167159
10	40	8	19	67	057500	057499
12	40	8	19	67	167172 o	167162 o
[mm]	[mm]	[mm]	[mm]	[mm]		

130215

## Dowel Bits HW

product

drawing

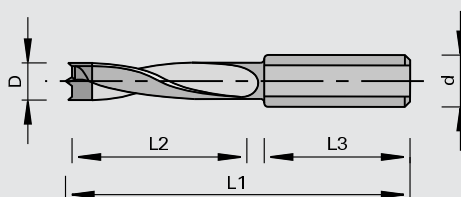

tungsten carbide [HW]

MAN

### Machine / Application

- | portable boring machines
- | automatic boring machines
- | CNC machining centers
- | for chip-free drilling of dowel holes in solid woods and wood-based panels

### Design

- | 2 negative spurs
- | centering point
- | spiral with back-guide
- | plastic coated
- | HW-tipped

### Advantages

- | chip-free hole edges thanks to negative spurs
- | safe drilling thanks to centering point
- | protection of the hole edge upon exiting thanks to spiral with back guide
- | optimum chip evacuation thanks to plastic coating

### Notes

- | adjusting screw Ident-No. 001600 M5x10 DIN 551 for precise length adjustment included in delivery
- | adjusting screw Ident-No. 181520 M5x11,5 for Weeke quick clamping chuck must be ordered separately
- | adjustable countersink attachment on the boring spiral for simultaneous chamfering of the hole
- | shell countersink Class-No. 130660
- | clamping elements: combi chuck, quick-change chuck

Ø D	L2	Ø d	L3	L1	Ident-No. [L]	Ident-No. [R]
5	30	10	19	57.5	167184	167174
6	30	10	20	57.5	167185	167175
7	30	10	20	57.5	167186	167176
8	30	10	20	57.5	167187	167177
10	30	10	20	57.5	167188	167178
12	30	10	20	57.5	167189	167179
13	30	10	20	57.5	167190 o	167180
14	30	10	20	57.5	167191	167181
15	30	10	20	57.5	167192	167182
16	30	10	20	57.5	167193 o	167183 o
5	43	10	19	70	167203	167194
6	43	10	19	70	167204	167195
8	43	10	19	70	167205	167196
9	43	10	19	70	167206 o	167197
10	43	10	19	70	167207	167198
12	43	10	19	70	167208	167199
[mm]	[mm]	[mm]	[mm]	[mm]		

130212

## Dowel Bits HW

product



drawing

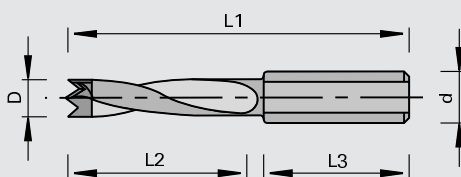

tungsten carbide [HW]

MAN

**Machine / Application**

- | portable boring machines
- | automatic boring machines
- | CNC machining centers
- | for chip-free drilling of dowel holes in solid woods and wood-based panels

**Design**

- | special cutting edge geometry
- | centering point
- | HW-tipped

**Advantages**

- | tool life increased up to tenfold compared to traditional dowel bits thanks to special HW and special grinding
- | chip-free hole edges thanks to special cutting edge geometry
- | safe drilling thanks to centering point

**Notes**

- | adjusting screw Ident-No. 001600 M5x10 DIN 551 for precise length adjustment included in delivery
- | adjusting screw Ident-No. 181520 M5x11,5 for Weeke quick clamping chuck must be ordered separately
- | clamping elements: combi chuck, quick-change chuck
- | other dimensions possible with minimum quantities of 10 pieces; price and delivery time on request

Ø D	L2	Ø d	L3	L1	Ident-No. [L]	Ident-No. [R]
5	30	8	19	55.5	178695	178696
4	20	10	27	57.5	179464	179465
5	25	10	27	57.5	177792	177793
6	25	10	27	57.5	177794	177795
8	25	10	27	57.5	177796	177797
10	30	10	27	57.5	178789	178788
4	20	10	30	70	179466	179467
5	35	10	30	70	177798	177799
6	35	10	30	70	177800	177801
8	35	10	30	70	177802	177803
10	35	10	30	70	178703	178704
[mm]	[mm]	[mm]	[mm]	[mm]		



130213

## Mosquito Dowel Bits HW

product



drawing

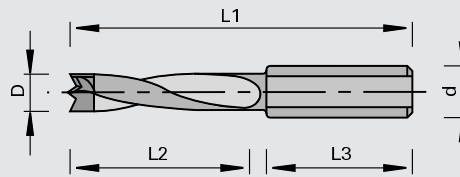

**MOSQUITO**

tungsten carbide [HW]

MAN

### Machine / Application

- | portable boring machines
- | automatic boring machines
- | CNC machining centers
- | for chip-free drilling of dowel holes in solid woods and wood-based panels

### Design

- | special cutting edge geometry
- | 2 spurs
- | centering point
- | HW-tipped

### Advantages

- | chip-free hole edges thanks to special cutting edge geometry with spurs
- | safe drilling thanks to centering point
- | high process safety thanks to constant quality of the bores for a long time
- | tool life increased up to sixfold compared to traditional dowel bits thanks to wear-resistant HW plunging tip

### Notes

- | adjusting screw Ident-No. 001600 M5x10 DIN 551 for precise length adjustment included in delivery
- | adjusting screw Ident-No. 181520 M5x11,5 for Weeke quick clamping chuck must be ordered separately
- | clamping elements: combi chuck, quick-change chuck

Ø D	L2	Ø d	L3	L1	Ident-No. [L]	Ident-No. [R]
5	25	10	27	57.5	181168	181167
6	25	10	27	57.5	181522	181521
8	25	10	27	57.5	181170	181169
10	25	10	27	57.5	181524	181523
5	35	10	30	70	181172	181171
6	35	10	30	70	181526	181525
8	35	10	30	70	181174	181173
10	35	10	30	70	181528	181527
[mm]	[mm]	[mm]	[mm]	[mm]		

130213

## Mosquito Dowel Bits with solid carbide body

product

drawing

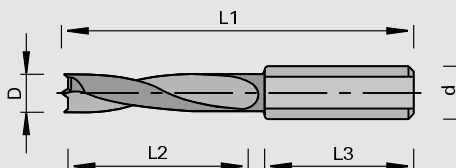

MOSQUITO

Solid Tungsten Carbide

MAN

**Machine / Application**

- | portable boring machines
- | automatic boring machines
- | CNC machining centers
- | for chip-free drilling of dowel holes in solid woods and wood-based panels

**Design**

- | special cutting edge geometry
- | 2 spurs
- | centering point
- | boring part made from fine-grain solid tungsten carbide

**Advantages**

- | chip-free hole edges thanks to special cutting edge geometry with spurs
- | safe drilling thanks to centering point
- | high feed rates and edge lives increased up to sixfold compared to traditional dowel bits thanks to solid carbide design
- | high process safety thanks to constant quality of the bores for a long time

**Notes**

- | adjusting screw Ident-No. 001600 M5x10 DIN 551 for precise length adjustment included in delivery
- | adjusting screw Ident-No. 181520 M5x11,5 for Weeke quick clamping chuck must be ordered separately
- | clamping elements: combi chuck, quick-change chuck

Ø D	L2	Ø d	L3	L1	Ident-No. [L]	Ident-No. [R]
3	9	10	35	57.5	183143 o	183142 o
3	18	10	31	57.5	182380	182381
4	20	10	29	57.5	182382 o	182383 o
5	22	10	27	57.5	182384	182385
6	22	10	25	57.5	183145 o	183144 o
8	22	10	25	57.5	183147 o	183146 o
3	18	10	43.5	70	182386	182387
4	27	10	34.5	70	182388	182389
5	30	10	31.5	70	182390	182391
6	30	10	30	70	183149	183148
8	30	10	30	70	183151	183150
[mm]	[mm]	[mm]	[mm]	[mm]		

130215

## Dowel Bits HW

product

drawing

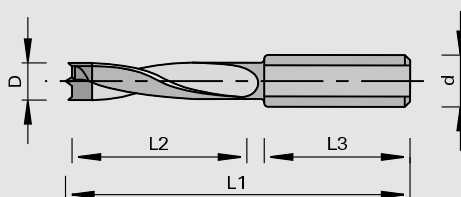

tungsten carbide [HW]

MAN

### Machine / Application

- | portable boring machines
- | automatic boring machines
- | CNC machining centers
- | for chip-free drilling of dowel holes in solid woods and wood-based panels

### Design

- | long cutting length
- | 2 negative spurs
- | centering point
- | spiral with back-guide
- | plastic coated
- | HW-tipped

### Advantages

- | deep holes thanks to long cutting length
- | chip-free hole edges thanks to negative spurs
- | safe drilling thanks to centering point
- | protection of the hole edge upon exiting thanks to spiral with back guide
- | optimum chip evacuation thanks to plastic coating

### Notes

- | adjustable countersink attachment on the boring spiral for simultaneous chamfering of the hole
- | shell countersink Class-No. 130660
- | adjusting screw Ident-No. 001600 M5x10 DIN 551 for precise length adjustment included in delivery
- | adjusting screw Ident-No. 181520 M5x11,5 for Weeke quick clamping chuck must be ordered separately
- | clamping elements: combi chuck, quick-change chuck

Ø D	L2	Ø d	L3	L1	Ident-No. [L]	Ident-No. [R]
5	45	10	30	85	177194	177193
5	65	10	30	105	177206 o	177205
6	45	10	30	85	177196 o	177195
6	65	10	30	105	177208 o	177207
7	45	10	30	85	177198	177197
7	65	10	30	105	177210	177209
8	45	10	30	85	177200	177199
8	65	10	30	105	177212	177211
10	45	10	30	85	177202	177201
10	65	10	30	105	177214	177213
12	45	10	30	85	177204	177203
12	65	10	30	105	177216 o	177215
[mm]	[mm]	[mm]	[mm]	[mm]		

130211

### Ecoline Dowel Bits HW

product

drawing

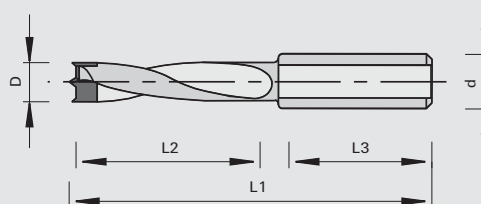

**LEUCO**  
**DUR**

tungsten carbide [HW]

MAN

**Machine / Application**

- | portable boring machines
- | automatic boring machines
- | CNC machining centers
- | for chip-free drilling of dowel holes in solid woods and wood-based panels

**Design**

- | 2 negative spurs
- | centering point
- | spiral without back guide
- | plastic coated
- | plunging tip with carbide plate for reduced demands

**Advantages**

- | chip-free hole edges thanks to negative spurs
- | safe drilling thanks to centering point
- | optimum chip evacuation thanks to plastic coating

**Notes**

- | adjusting screw Ident-No. 001600 M5x10 DIN 551 for precise length adjustment included in delivery
- | adjusting screw Ident-No. 181520 M5x11,5 for Weeke quick clamping chuck must be ordered separately
- | clamping elements: combi chuck, quick-change chuck

Ø D	L2	Ø d	L3	L1	Ident-No. [L]	Ident-No. [R]
5	26	10	20	57.5	183375	183374
8	31	10	20	57.5	183377	183376
10	32	10	20	57.5	183379	183378
5	39	10	20	70	183381	183380
6	40	10	20	70	183383	183382
8	44	10	20	70	183385	183384
10	45	10	20	70	183387	183386
[mm]	[mm]	[mm]	[mm]	[mm]		



130217

## Dowel Bits HW

product



drawing

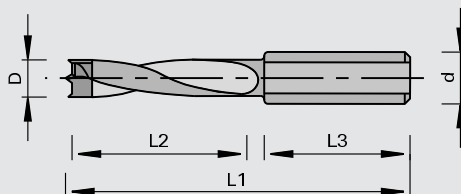

tungsten carbide [HW]

MAN

### Machine / Application

- | portable boring machines
- | automatic boring machines
- | CNC machining centers
- | for chip-free drilling of dowel holes in solid woods and wood-based panels

### Design

- | 2 negative spurs
- | centering point
- | spiral without back guide
- | plastic coated
- | HW-tipped

### Advantages

- | chip-free hole edges thanks to negative spurs
- | safe drilling thanks to centering point
- | optimum chip evacuation thanks to plastic coating

### Notes

- | adjusting screw Ident-No. 001600 M5x10 DIN 551 for precise length adjustment included in delivery
- | adjusting screw Ident-No. 181520 M5x11,5 for Weeke quick clamping chuck must be ordered separately
- | clamping elements: combi chuck, quick-change chuck

Ø D	L2	Ø d	L3	L1	Ident-No. [L]	Ident-No. [R]
4.0	27	10	27	57.5	003175	003174
4.5	27	10	27	57.5	177228	177227
5.0	27	10	27	57.5	003179	003178
5.1	27	10	27	57.5	177230	177229
5.2	27	10	27	57.5	167707 o	167708 o
6.0	27	10	27	57.5	003183	003182
7.0	27	10	27	57.5	003187	003186
8.0	27	10	27	57.5	003191	003190
8.2	27	10	27	57.5	167216	167213
9.0	27	10	27	57.5	003195	003194
10.0	27	10	27	57.5	003199	003198
10.5	27	10	27	57.5	182261 o	182262 o
11.0	27	10	27	57.5	177232 o	177231
12.0	27	10	27	57.5	003207	003206
4.0	35	10	30	70	173175	173174
4.5	35	10	30	70	182263 o	182264 o
5.0	35	10	30	70	003231	003230
5.1	35	10	30	70	182265 o	182266 o
5.5	35	10	30	70	182267	182268 o
6.0	35	10	30	70	003235	003234
6.5	35	10	30	70	182269 o	182270 o
7.0	35	10	30	70	167224	167219
7.5	35	10	30	70	182271 o	182272 o
8.0	35	10	30	70	003243	003242
8.1	35	10	30	70	182273 o	182274 o
8.2	35	10	30	70	182275	182276 o
8.5	35	10	30	70	182277 o	182278 o
9.0	35	10	30	70	167225	167220
10.0	35	10	30	70	003251	003250
10.2	35	10	30	70	182279 o	182280 o
11.0	35	10	30	70	167226	167221
12.0	35	10	30	70	167227	167222
13	35	10	30	70	183042	183043
14	35	10	30	70	183044	183045
16	35	10	30	70	183046	183047
5.0	44	10	30	77	167233	167228
6.0	44	10	30	77	167234	167229
[mm]	[mm]	[mm]	[mm]	[mm]		

Ø D	L2	Ø d	L3	L1	Ident-No. [L]	Ident-No. [R]
8.0	44	10	30	77	167235	167230
10.0	44	10	30	77	167236	167231
12.0	44	10	30	77	173181	173180
[mm]	[mm]	[mm]	[mm]	[mm]		

330215  
Dowel Bits HS

product

drawing

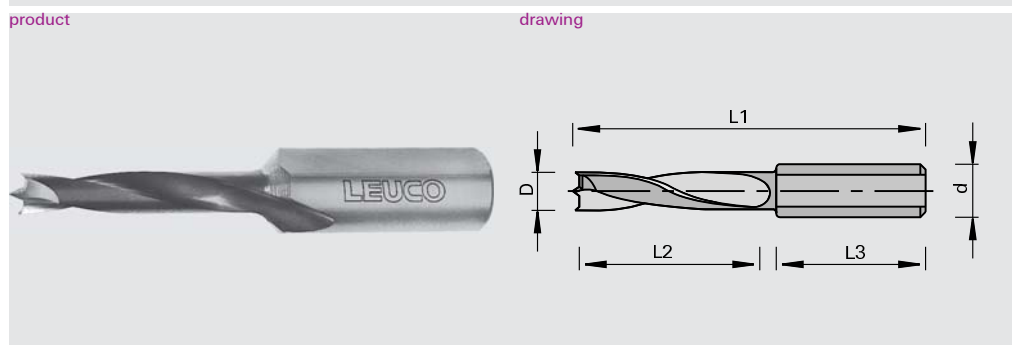

High Speed Steel [HS]
MAN

Machine / Application

- | portable boring machines
- | automatic boring machines
- | for drilling of dowel holes in solid woods

Design

- | 2 spurs
- | centering point
- | spiral with back-guide
- | HS design

Advantages

- | chip-free hole edges thanks to spurs
- | safe drilling thanks to centering point
- | protection of the hole edge upon exiting thanks to spiral with back guide

Notes

- | clamping element: combi chuck, quick-change chuck

Ø D	L2	Ø d	L3	L1	Ident-No. [L]	Ident-No. [R]
4	30	10	20	57.5	177234 o	177233 o
5	30	10	20	57.5	177236 o	177235 o
6	30	10	20	57.5	177238 o	177237 o
8	30	10	20	57.5	177240 o	177239 o
10	30	10	20	57.5	177242 o	177241 o
5	43	10	20	70	177246	177245
6	43	10	20	70	160479 o	177247 o
7	43	10	20	70	177250 o	177249 o
8	43	10	20	70	177248	160475 o
10	43	10	20	70	177252 o	177251 o
12	43	10	20	70	177254 o	177253 o
14	43	10	20	70	177256 o	177255 o
16	43	10	20	70	177258 o	177257 o
6	65	10	30	105	177274 o	177273 o
8	65	10	30	105		177277 o
10	65	10	30	105	177280 o	177279 o
12	65	10	30	105	177282 o	177281 o
[mm]	[mm]	[mm]	[mm]	[mm]		

330215

### Dowel Bits HS

product



drawing

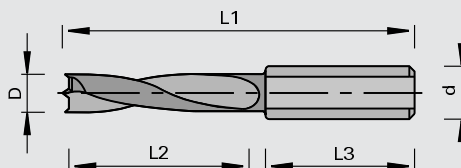

High Speed Steel [HS]

MAN

**Machine / Application**

- | portable boring machines
- | automatic boring machines
- | for drilling of dowel holes in solid woods

**Design**

- | 2 spurs
- | centering point
- | spiral without back guide
- | HS design

**Advantages**

- | chip-free hole edges thanks to spurs
- | safe drilling thanks to centering point

**Notes**

- | clamping element: combi chuck, quick-change chuck

Ø D	L2	Ø d	L3	L1	Ident-No. [L]	Ident-No. [R]
5	45	10	30	85	177260 o	177259 o
6	45	10	30	85		177261 o
8	45	10	30	85	177266 o	177265 o
10	45	10	30	85	177268 o	177267 o
12	45	10	30	85	177270 o	177269 o
[mm]	[mm]	[mm]	[mm]	[mm]		

130226

### Dowel Bits HW

product



drawing

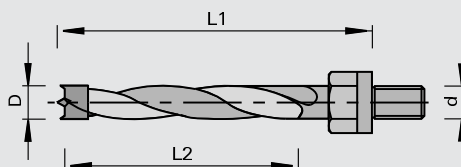

tungsten carbide [HW]

MAN

**Machine / Application**

- | portable boring machines
- | automatic boring machines
- | for chip-free drilling of dowel holes in solid woods and wood-based panels

**Design**

- | 2 negative spurs
- | centering point
- | spiral without back guide
- | plastic coated
- | threaded shank
- | HW-tipped

**Advantages**

- | chip-free hole edges thanks to negative spurs
- | safe drilling thanks to centering point
- | optimum chip evacuation thanks to plastic coating
- | high stability thanks to threaded shank for direct clamping onto the boring spindle

**Notes**

- | for coordination with machines see section Clamping Systems

Ø D	L2	Ø d	L1	Ident-No. [L]	Ident-No. [R]
5	45	M8	63	160570 o	160566 o
5	45	M10	63	167697	167698
6	45	M10	63	160576 o	160574 o
8	45	M8	63	160572 o	160568 o
8	45	M10	63	160577	160575
10	45	M10	63	167699 o	167700 o
12	45	M8	63	167691 o	167692 o
12	45	M10	63	167701 o	167702 o
[mm]	[mm]	[mm]	[mm]		

130226

## Dowel Bits HW

product

drawing

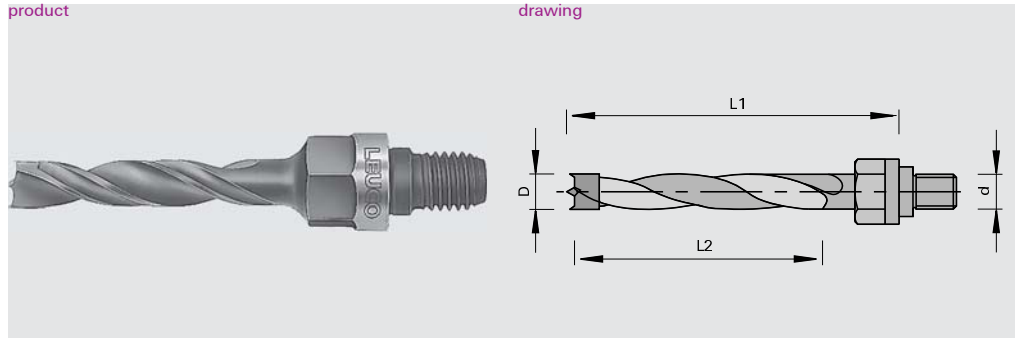

<b>LEUCO DUR</b>
tungsten carbide [HW]
MAN

**Machine / Application**

- | portable boring machines
- | automatic boring machines
- | for chip-free drilling of dowel holes in solid woods and wood-based panels

**Design**

- | 2 negative spurs
- | centering point
- | spiral without back guide
- | plastic coated
- | threaded shank
- | HW-tipped

**Advantages**

- | chip-free hole edges thanks to negative spurs
- | safe drilling thanks to centering point
- | optimum chip evacuation thanks to plastic coating
- | high stability thanks to threaded shank for direct clamping onto the boring spindle

**Notes**

- | for coordination with machines see section Clamping Systems

Ø D	L2	Ø d	L1	Ident-No. [L]	Ident-No. [R]
5	45	M10	63	167703 o	167704 o
6	45	M10	63	167705 o	167706 o
8	45	M10	63	160584	160582
10	45	M10	63	160585 o	160583 o
[mm]	[mm]	[mm]	[mm]		





130214

## High-Performance Dowel Bits with solid carbide body

product

drawing

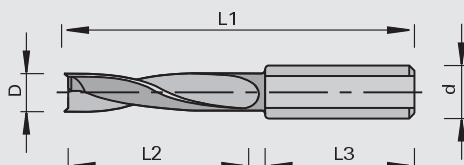

Solid Tungsten Carbide

MEC

**Machine / Application**

- | stationary boring machines
- | automatic boring machines
- | CNC machining centers
- | for drilling of through holes and dowel holes in solid woods, wood-based panels and composite materials

**Design**

- | special cutting edge geometry
- | 2 spurs
- | spiral with back-guide
- | boring part made from solid tungsten carbide

**Advantages**

- | special tooth geometry and spurs for minimal cutting force and cutting pressure
- | protection of the hole edge upon exiting thanks to spiral with back guide
- | high feed rates and large resharpenable area thanks to solid carbide bit

**Notes**

- | adjusting screw Ident-No. 001600 M5x10 DIN 551 for precise length adjustment included in delivery
- | adjusting screw Ident-No. 181520 M5x11,5 for Weeke quick clamping chuck must be ordered separately
- | clamping elements: combi chuck, quick-change chuck
- | tooth geometry applied for patent
- | change of grinding or reduction of diameter ist not possible

Ø D	L2	Ø d	L3	L1	Ident-No. [L]	Ident-No. [R]
5	32	10	22	57.5	182815	182814
8	32	10	22	57.5	182819	182818
5	36	10	30	70	182825	182824
6	36	10	30	70	182827	182826
8	36	10	30	70	182829	182828
10	36	10	30	70	182831	182830
[mm]	[mm]	[mm]	[mm]	[mm]		

230215

## Dowel Bits DP

product

drawing

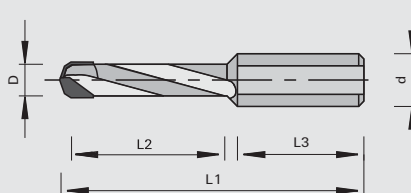

polycrystalline diamond [DP]

MEC

**Machine / Application**

- | automatic boring machines
- | CNC machining centers
- | for chip-free drilling in raw and laminated panels and composite materials

**Design**

- | special cutting edge geometry, 2 DP rakers which form a double chamfer
- | spiral without back guide
- | DP-tipped

**Advantages**

- | long edge life when machining extremely abrasive materials
- | chip-free hole edges thanks to special cutting edge geometry

**Notes**

- | adjusting screw Ident-No. 001600 M5x10 DIN 551 for precise length adjustment included in delivery
- | adjusting screw Ident-No. 181520 M5x11,5 for Weeke quick clamping chuck must be ordered separately
- | clamping elements: combi chuck, quick-change chuck

Ø D	L2	Ø d	L3	L1	Z	Ident-No. [L]	Ident-No. [R]
5	27	10	26	57.5	2	183005 s	183004 s
6	27	10	26	57.5	2	183007 s	183006 s
8	27	10	26	57.5	2	183009 s	183008 s
5	35	10	30	70	2	183011 s	183010 s
6	35	10	30	70	2	183051 s	183052 s
8	35	10	30	70	2	183013 s	183012 s
10	35	10	30	70	2	183053 s	183054 s
[mm]	[mm]	[mm]	[mm]	[mm]			

130010

### Boring spikes with solid carbide body

product

drawing

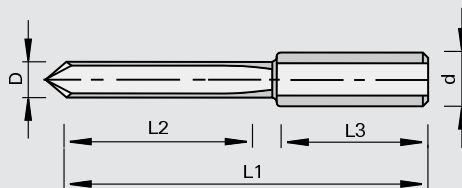

Solid Tungsten Carbide

MAN

**Machine / Application**

- | automatic boring machines
- | CNC machining centers
- | for drilling of dowel holes in wood-based panels

**Design**

- | cylindrical shank  $\varnothing 10$  mm with clamping surface and adjusting screw
- | solid carbide design

**Advantages**

- | large resharpenable area
- | long edge lives

**Notes**

- | for clockwise and counter-clockwise rotation
- | clamping element: combi chuck, quick-clamping chuck

$\varnothing D$	L2	$\varnothing d$	L3	L1	Ident-No.
2.0	12	2,0		38	183059
2.5	12	2,5		45	180942
3	12	3		45	180943
3.5	15	3,5		45	183060
4	12	4		45	180944 o
2.5	15	10	33	57.5	183061 o
3	15	10	33	57.5	183062 o
5	25	10	25	57.5	180945 o
3.5	30	10	24	70	183063 o
4	32	10	25	70	183064 o
5	35	10	25	70	180946 o
[mm]	[mm]	[mm]	[mm]	[mm]	

130710

## Boring Countersink HW

product

drawing

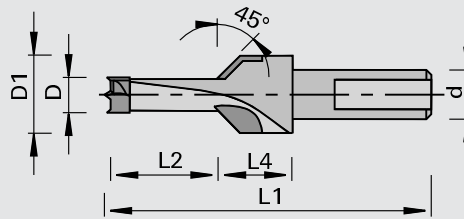

tungsten carbide [HW]

MAN

**Machine / Application**

- | portable boring machines
- | automatic boring machines
- | for drilling and countersinking in solid woods and wood-based panels

**Design**

- | spiral PTFE coated
- | 2 spurs
- | centering point

**Advantages**

- | for drilling and countersinking in one pass
- | safe drilling thanks to centering point

**Notes**

- | adjusting screw Ident-No. 001600 M5x10 DIN 551 for precise length adjustment included in delivery
- | adjusting screw Ident-No. 181520 M5x11,5 for Weeke quick clamping chuck must be ordered separately
- | clamping elements: combi chuck, quick-clamping chuck

Ø D	L2	Ø D1	L4	Ø d	L1	Ident-No. [L]	Ident-No. [R]
8	12	16	15	10	57.5	180847	180846
8	15	16	15	10	57.5	180849	180848
10	12	16	15	10	57.5	180853	180852
10	15	16	15	10	57.5	180855 o	180854 o
8	12	16	15	10	70	180859	180858
8	20	16	15	10	70	180863	180862
10	12	16	15	10	70	180865	180864
10	20	16	15	10	70	180869 o	180868 o
[mm]	[mm]	[mm]	[mm]	[mm]	[mm]		

130660

## Countersink Parts HW to be mounted on Twist Drills and Dowel Bits

product

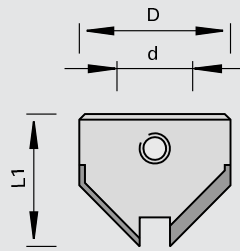

drawing

LEUCO  
DUR

tungsten carbide [HW]

MAN

Machine / Application

- for drilling of countersinks in solid woods and wood-based panels
- for chip-free countersink holes at 90 degree angle

Design

- HW-tipped

Advantages

Notes

- for installation on twist drills and dowel bits with back-guide on the drill spiral with set screw
- continuous adjustment of the countersink diameter and the boring depth

$\varnothing D$	$\varnothing d$	L1	Ident-No. [L]	Ident-No. [R]
15.5	3	17.5		177291
16	4	16	183811 o	183812
16	5	16	183174	183175
16	6	16	183176	183177
16	7	16	183178	183179
18	8	16	183180	183181
18	9	16	183813 o	183814 o
20	10	16	183182	183183
20	12	16	183815 o	183816
[mm]	[mm]	[mm]		

spare parts

Dimension

Class-No.

Ident-No.

Set Screws	M6x4 DIN EN ISO 4029	995161	167068
Cranked Wrench Keys	SW3 DIN ISO 2936	985730	009672
	[mm]		

130660

## Countersink Parts HW to be mounted on Dowel Bits

product

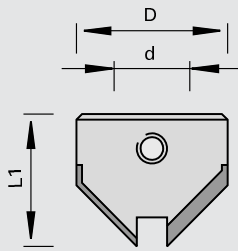

drawing

LEUCO  
DUR

tungsten carbide [HW]

MAN

## Machine / Application

- for drilling of countersinks in solid woods and wood-based panels
- for chip-free countersink holes at 90 degree angle

## Design

- HW-tipped

## Advantages

## Notes

- for installation on elongated shank of dowel bits  $\varnothing$  5 - 12 mm with setscrew
- continuous adjustment of the countersink diameter and the boring depth

$\varnothing$ D	$\varnothing$ d	L1	Ident-No. [L]	Ident-No. [R]
15.5	10	16.5	177294	177293
20	10	16	183184	183185
22	10	16.5		177295 o
[mm]	[mm]	[mm]		

spare parts	Dimension	for Ident-No.	Class-No.	Ident-No.
Set Screws	M6x4 DIN EN ISO 4029	169312, 177293	995161	167068
Set Screws	M6x5 DIN EN ISO 4029	177295	995161	165049
Cranked Wrench Keys	SW3 DIN ISO 2936		985730	009672
	[mm]			

130660

## Countersink Bits HW for Twist Drills

product

drawing

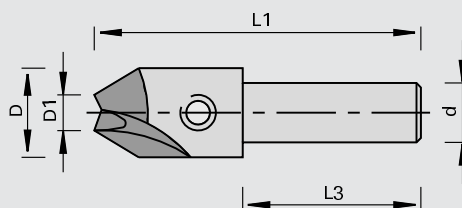

tungsten carbide [HW]

MAN

**Machine / Application**

- for drilling of countersinks in solid woods and wood-based panels
- for chip-free countersink holes at 90 degree angle

**Design**

- HW-tipped

**Advantages**

**Notes**

- for mounting of twist drills with  $\varnothing$  3 - 6 mm
- continuous adjustment of the countersink diameter and the boring depth

$\varnothing$ D	$\varnothing$ D1	$\varnothing$ d	L3	L1		Ident-No.
15	3.0	10	30	58	R	173190
15	3.0	10	30	58	L	173191 o
15	3.5	10	30	58	R	173192
15	4.0	10	30	58	R	173194
15	4.0	10	30	58	L	173195
15	4.5	10	30	58	R	173196
15	4.5	10	30	58	L	173197 o
15	5.0	10	30	58	R	173198
15	5.0	10	30	58	L	173199
15	6.0	10	30	58	R	173202 o
15	6.0	10	30	58	L	173203 o
[mm]	[mm]	[mm]	[mm]	[mm]		

**spare parts**

**Dimension**

**Class-No.**

**Ident-No.**

Set Screws	M6x6 DIN EN ISO 4029 [mm]	995161	180003
------------	------------------------------	--------	--------

130135

## Cylinder Boring Bits with HW insert

product

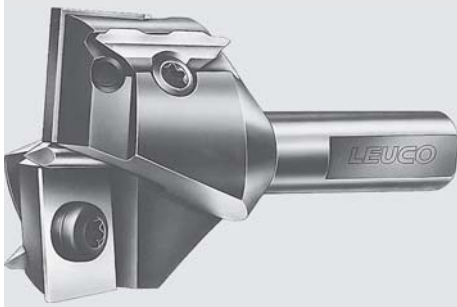

drawing

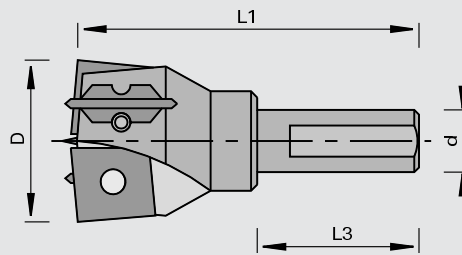

tungsten carbide [HW]

MAN

**Machine / Application**

- | hardware hinge machines
- | automatic boring machines
- | CNC machining centers
- | for chip-free drilling of hinge hardware holes in solid woods and wood-based panels

**Design**

- | 2 rakers, 2 turnover spurs and centering point

**Advantages**

- | long edge lives thanks to wear-resistant HW grade
- | chip-free hardware hinge holes thanks to scoring cut of the turnover spurs

**Notes**

- | replaceable and adjustable centering point
- | cylindrical shank with clamping surface
- | adjusting screw Ident-No. 001600 M5x10 DIN 551 for precise length adjustment included in delivery
- | adjusting screw Ident-No. 181520 M5x11,5 for Weeke quick clamping chuck must be ordered separately
- | clamping elements: combi chuck, quick-clamping chuck

Ø D	Ø d	L3	L1	Ident-No. [L]	Ident-No. [R]
25	10	26	57.5		162612
26	10	26	57.5	162615 #	162614
30	10	26	57.5		162616
35	10	26	57.5	162619	162618
25	10	26	70		182570
26	10	26	70		182571
30	10	26	70		182572
35	10	26	70		182573
[mm]	[mm]	[mm]	[mm]		

Turnover Knives	Dimension	for Ident-No.	Class-No.	Ident-No.
Turnover Knives	10,5x12x1,5	162612, 182570	150515	162636
Turnover Knives	11x12x1,5	162614, 162615, 182571	150515	162637
Turnover Knives	13x12x1,5	162616, 182572	150515	162638
Turnover Knives	15,7x12x1,5	162618, 162619, 182573	150515	163846
Spurs	18x6x3,5		150558	181263
Centering Points	3x33,5 [mm]		165512	162624

spare parts	Dimension	for Ident-No.	Class-No.	Ident-No.
Set Screws	M6x6 DIN EN ISO 4028		995161	163841
Countersunk Flat Headed Screws	M3,5x6 T15	162614, 162615, 162616, 162618, 162619, 182571, 182572, 182573	995125	162648
Countersunk Flat Headed Screws	M3,5x5,5 T15	162612, 182570	995125	162649
Head Cap Screws	M3,5x3,8 T15 [mm]		995115	162645



130117

## Cylinder Boring Bits HW

product



drawing

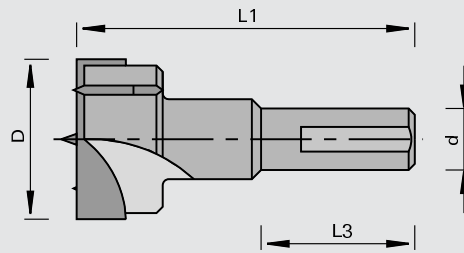

tungsten carbide [HW]

MAN

**Machine / Application**

- | hardware hinge machines
- | automatic boring machines
- | CNC machining centers
- | for chip-free drilling of hinge hardware holes in solid woods and wood-based panels

**Design**

- | 2 rakers, 2 spurs and centering point
- | HW-tipped

**Advantages**

- | chip-free holes thanks to scoring cut of the spurs

**Notes**

- | cylindrical shank with clamping surface
- | adjusting screw Ident-No. 001600 M5x10 DIN 551 for precise length adjustment included in delivery
- | adjusting screw Ident-No. 181520 M5x11,5 for Weeke quick clamping chuck must be ordered separately
- | clamping elements: combi chuck, quick-clamping chuck

Ø D	Ø d	L3	L1	Ident-No. [L]	Ident-No. [R]
15	10	26	57.5	003303	003302
16	10	26	57.5	003305	003304
18	10	26	57.5	003309	003308
20	10	26	57.5	003313	003312
22	10	26	57.5	003315	003314
25	10	26	57.5	003319	003318
26	10	26	57.5	003321	003320
30	10	26	57.5	003327	003326
35	10	26	57.5	003333	003332
40	10	26	57.5	003337	003336
15	10	26	70	178978	172250
18	10	26	70	178983	178984
20	10	26	70	178979	172251
22	10	26	70	182257	182258
25	10	26	70	178980	172252
26	10	26	70	182374	182375
30	10	26	70	178981	172253
35	10	26	70	178982	172254
40	10	26	70	182259	182260
[mm]	[mm]	[mm]	[mm]		

130119

## Cylinder Boring Bits HW

product



drawing

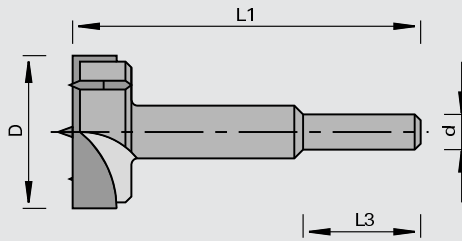

tungsten carbide [HW]

MAN

**Machine / Application**

- portable boring machines
- for chip-free drilling in solid woods and wood-based panels

**Design**

- 2 rakers, 2 spurs and centering point
- HW-tipped
- Ø 12: spurs in rakers
- cylindrical shank

**Advantages**

- chip-free holes thanks to scoring cut of the spurs

**Notes**

- clamping element: drill chuck

Ø D	Ø d	L3	L1	Ident-No.
12	10	62	90	173204 o
14	10	60	90	167685
15	10	60	90	160424
16	10	60	90	160425
17	10	60	90	167686
18	10	60	90	160426
19	10	60	90	167687
20	10	60	90	160427
21	10	60	90	173205
22	10	60	90	160428
23	10	60	90	167688
24	10	60	90	160429
25	10	60	90	160430
26	10	60	90	160431
27	10	74	90	173206 o
28	10	60	90	160432
30	10	60	90	160433
32	10	60	90	160434
34	10	74	90	167689 o
35	10	60	90	160435
36	10	30	90	160436 o
38	10	60	90	160437 o
40	10	60	90	160438
42	10	30	90	167690 o
45	10	60	90	173207
50	10	60	90	173208
[mm]	[mm]	[mm]	[mm]	



130111

## Cylinder Boring Bits HW

product



drawing

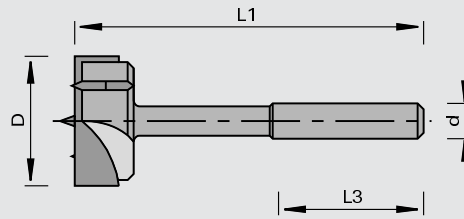

tungsten carbide [HW]

MAN

**Machine / Application**

- | portable boring machines
- | for chip-free drilling in solid woods and wood-based panels

**Design**

- | 2 rakers, 2 spurs and centering point
- | HW-tipped

**Advantages**

- | chip-free holes thanks to scoring cut of the spurs

**Notes**

- | diameter of the cylindrical shank is adapted to the cutting pressure
- | clamping element: drill chuck

Ø D	Ø d	L3	L1	Ident-No.
15	13	50	140	173210 o
16	13	50	140	173211 o
18	13	50	140	160388 o
20	13	50	140	160389 o
22	13	50	140	160390 o
24	13	50	140	173212 o
25	13	50	140	160392 o
26	13	50	140	160393 o
28	13	50	140	160394 o
30	13	50	140	160395 o
32	16	50	140	160396 o
34	16	50	140	173213 o
35	16	50	140	160398 o
38	16	50	140	173215 o
40	16	50	140	160401 o
42	16	50	140	160402 o
44	16	50	140	173216 o
45	16	50	140	180742 o
46	16	50	140	173217 o
48	16	50	140	173218 o
50	16	50	140	160407 o
52	16	50	140	160408 o
54	16	50	140	173219 o
55	16	50	140	160409 o
56	16	50	140	173220 o
58	16	50	140	173221 o
60	16	50	140	160410 o
63	16	50	140	173228 o
65	16	50	140	160411 o
68	16	50	140	173222 o
70	16	50	140	160412 o
75	20	50	140	173223 o
80	20	50	140	160414 o
90	20	50	140	173225 o
[mm]	[mm]	[mm]	[mm]	

130115

## Cylinder Boring Bits HW

product



drawing

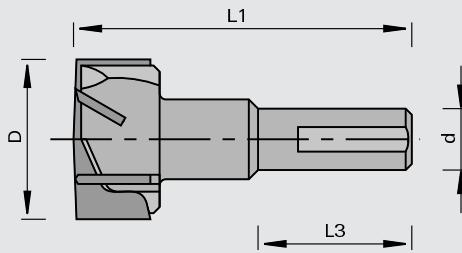

tungsten carbide [HW]

MAN

**Machine / Application**

- | hardware hinge machines
- | automatic boring machines
- | CNC machining centers
- | for chip-free drilling in solid woods and wood-based panels

**Design**

- | 3 rakers, 3 spurs, without centering point
- | HW-tipped

**Advantages**

- | boring depths close to the bottom-side laminate
- | chip-free holes thanks to scoring cut of the spurs
- | high feed rates thanks to Z = 3+3

**Notes**

- | cylindrical shank with clamping surface
- | adjusting screw Ident-No. 001600 M5x10 DIN 551 for precise length adjustment included in delivery
- | adjusting screw Ident-No. 181520 M5x11,5 for Weeke quick clamping chuck must be ordered separately
- | clamping elements: combi chuck, quick-clamping chuck

Ø D	Ø d	L3	L1	Ident-No. [L]	Ident-No. [R]
25	10	26	57.5	160385	160384
26	10	26	57.5		003278
30	10	26	57.5		003280
35	10	26	57.5	003285	003284
40	10	26	57.5		713347 o
[mm]	[mm]	[mm]	[mm]		

230115

## Cylinder Boring Bits DP

product

drawing

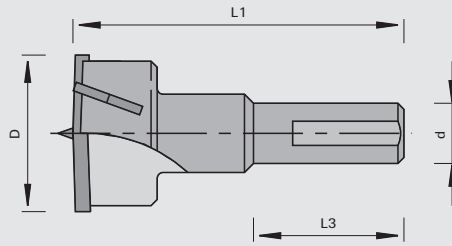

polycrystalline diamond [DP]

MEC

**Machine / Application**

- | automatic boring machines
- | CNC machining centers
- | for chip-free drilling in raw and laminated panels

**Design**

- | 2 DP rakers, 2 DP spurs
- | HW Centering point
- | resharpenable several times

**Advantages**

- | long edge life when machining abrasive materials
- | economic efficiency thanks to possibility to resharpen several times
- | chip-free holes thanks to scoring cut of the spurs
- | safe drilling thanks to centering point

**Notes**

- | cylindrical shank with clamping surface
- | adjusting screw Ident-No. 001600 M5x10 DIN 551 for precise length adjustment included in delivery
- | adjusting screw Ident-No. 181520 M5x11,5 for Weeke quick clamping chuck must be ordered separately
- | clamping elements: combi chuck, quick-clamping chuck

Ø D	Ø d	L3	L1	Z	Ident-No. [L]	Ident-No. [R]
15	10	26	57.5	2+2	182995 s	182994 s
20	10	26	57.5	2+2	182997 s	182996 s
25	10	26	57.5	2+2	182999 s	182998 s
30	10	26	57.5	2+2	183001 s	183000 s
35	10	26	57.5	2+2	183048 s	183002 s
[mm]	[mm]	[mm]	[mm]			

## Quick-Change Systems for Boring Bits

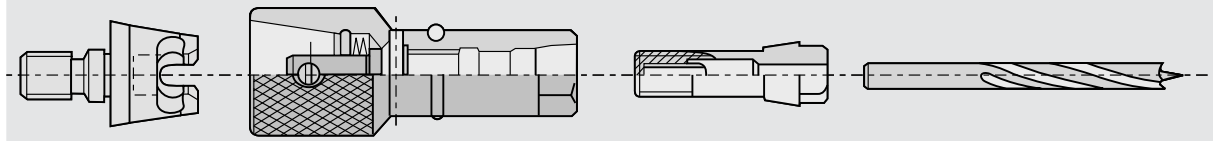

features	Advantages	benefit
precise tapered adapter	precise radial running accuracy of the boring bit	improved product quality
tight connection	tight connection between boring bit and machine	safe operation
simple locking	quick change of the boring bit	short downtimes
color-coded top part to mark the direction of rotation	quick and easy recognition of the direction of rotation	no high demands on the machine operators
compatible with old "Klack" and combi chuck	upgrading and partial equipping of existing machines possible	low cost

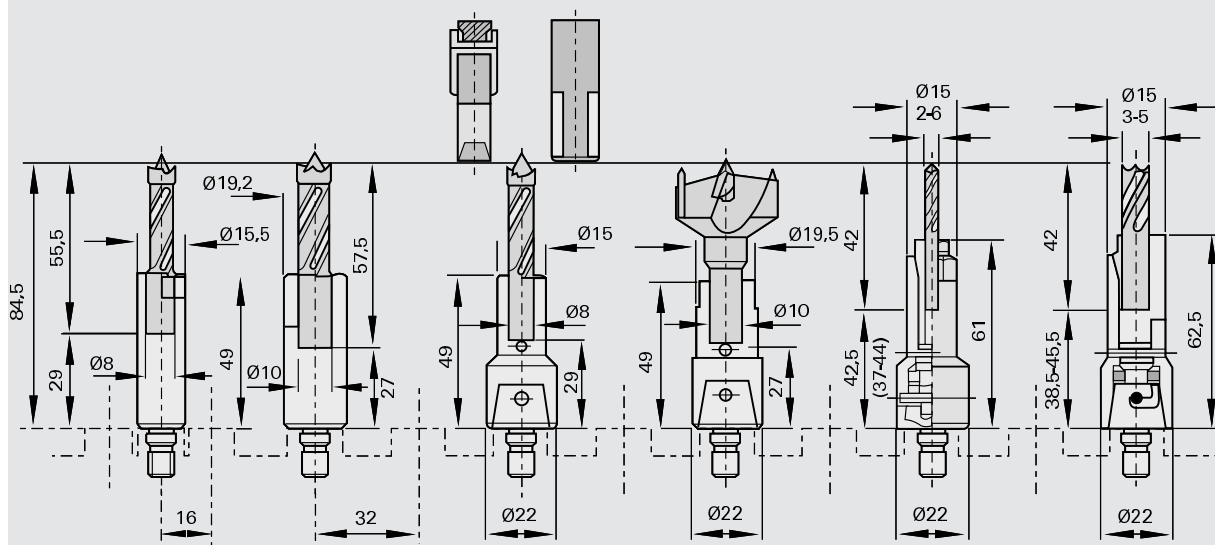

## Order / Inquiry for Special Tools: Drill Bits / Plunge Cutters

Please copy and send the completed form to one of the LEUCO sales offices. (Only one tool description per form)

customer-no.:	_____	order:	<input type="radio"/>
company:	_____	inquiry:	<input type="radio"/>
plant:	_____		
street:	_____	delivery (week no.):	_____
zip / city:	_____	(not binding)	
country:	_____	no. of pieces:	_____
contact partner:	_____		
phone:	_____	fax:	_____
city and date:	_____	signature:	_____

### machine

make: \_\_\_\_\_

model: \_\_\_\_\_

type: \_\_\_\_\_

operating RPM [min-1]: \_\_\_\_\_

feed rate [m/min]: \_\_\_\_\_

### workpiece material

description: \_\_\_\_\_

through hole:

blind hole:

boring depth [mm]: \_\_\_\_\_

### coating

yes  no

description: \_\_\_\_\_

further information \_\_\_\_\_

### product line

Topline

standard

### cutting material

carbide

Diamond

HS

### tool

Twist Drills

Through-Hole Bits

Dowel Bits

shell countersink

countersink for twist drill bits

cylinder boring bit

brazed

with turnover knives

bore diameter D [mm]: \_\_\_\_\_

effective length L2 [mm]: \_\_\_\_\_

overall length L1 [mm]: \_\_\_\_\_

shank length L3 [mm]: \_\_\_\_\_

shank design d:

cylindrical shank [Ø]: \_\_\_\_\_

other shank types: \_\_\_\_\_

type (per enclosure): \_\_\_\_\_

no. of cutting edges: \_\_\_\_\_

rakers: \_\_\_\_\_

spur: \_\_\_\_\_

sense of rotation: right  left

check if applicable

Please indicate additional dimension and markings in the tool drawing.

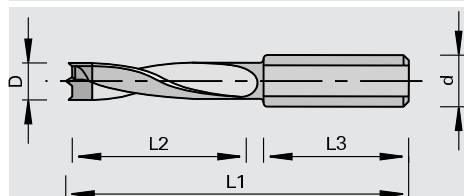

520-01.0708